

Option Cards

The AC20F Series supports the addition of Option Cards (purchased separately):

1. Encoder Feedback: For precise vector control using an encoder on the motor (wiring example below. For setup, refer to the Hardware Installation Manual):

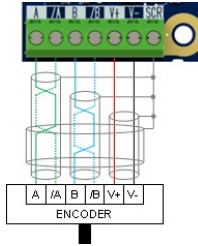

2. General Purpose Input / Output (GPIO): For expansion of the drives' analogue and digital IO.

Note: Any combination of option card is valid - i.e., the option cards can be fitted in either slot position, and two of the same type can be fitted at the same time.

Communication Cards

The AC20F Series also supports the addition of a Communication Card (purchased separately). Communication protocols offered are:

- 2003-CN-00: CANopen
- 2003-EC-00: EtherCAT
- 2003-IP-00: Ethernet IP
- 2003-PB-00: Profibus DVP1
- 2003-PN-00: ProfiNet
- 2003-RS-00: RS485/Modbus RTU

Applying an external 24V supply to the relevant control terminals will allow communication and programming when the line voltage to the product is disabled:

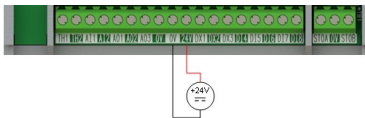

Associated Literature

MSG11-5715-743:

AC20F Series Hardware Installation Manual

MSG11-5715-744:

AC20F Series Software Reference Manual



ENGINEERING YOUR SUCCESS.

AC20F Series

Variable Speed Drive

Frames 6 - 10

(37 - 180kW)



Before You Start

This document covers the basic start up of the AC20F Series drive. Drive start ups should be performed by qualified electrical technicians who are familiar with AC drives and their applications. For detailed installation and safety information, refer to the Hardware Installation Manual. For advanced features and applications, refer to the Software Reference Manual.

Ensure that all local electric codes are met while installing the drive. Check that all live parts are covered to protect against electric shock and that unexpected rotation of the motor will not result in bodily harm or injury.

This document expects that the drive is already installed in its intended location and that all relevant installation procedures have been followed. Please ensure that the drive has adequate ventilation so that ambient temperature does not exceed 40°C (104°F) under normal operating conditions.

Frame Ratings

The AC20F Series is available in 400V three phase line input voltage version, covered by Frame sizes 2-10. The Frame 6-10 ratings, as covered by this Quick Start, are shown below.

400V, 3ø Supply	
Frame 6	37 - 45kW
Frame 7	55 - 75kW
Frame 8	90 - 132kW
Frame 9	160kW
Frame 10	180kW

Compatible Motors

This product supports both Induction and Permanent Magnet (PMAC) motor types.

Control Modes

The AC20F Series offers three control modes:

1. Volts/Hertz Mode (V/Hz): Basic open-loop operation used in fan/pump and multi-motor applications. **Note: Induction Motors only.**

2. Sensorless Vector (SLV) Mode: Tight speed regulation with good transient torque capability, without the need for speed feedback.

3. Encoder Feedback Mode: Precise vector control with full torque down to zero speed, and improved dynamic performance. Requires Encoder Feedback option card and an encoder on the motor. **Note: Induction Motors only.**

Power Connections

To access the power connections:

1. Remove the lower terminal cover.
2. Remove (Fr 6 & 7), or slide out the way (Fr 8 - 10) the terminal guard.

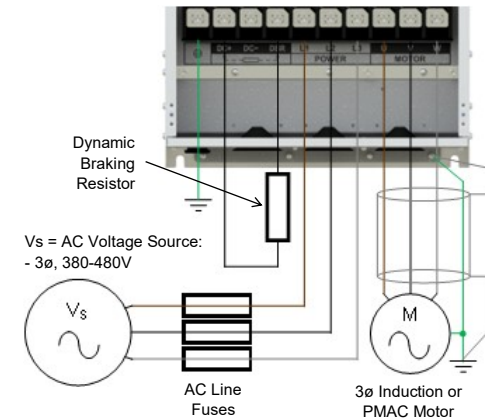

Note: Power terminals shown are for Frame 7. Although other frames may vary slightly in appearance and sequence, their terminal designations and functionality are identical.

Label	Description
PE	Protective Earth
DC+	DC+ / Dynamic Brake Resistor '+'
DC-	DC-
DBR	Dynamic Brake Resistor '-'
L1	Supply Input Phase L1
L2	Supply Input Phase L2
L3	Supply Input Phase L3
U	Motor Output Phase U
V	Motor Output Phase V
W	Motor Output Phase W

PE Connections: The Chassis PE connection points are connected internally to the PE terminal. Please follow proper grounding and shielding methods as described in the Hardware Installation Manual.

Dynamic Brake Resistor (DBR): If the stop time required by the end application is less than the natural coasting time of the load, connect a suitably rated Braking Resistor between the DC+ and DBR terminals.

Note: Additional Brake Resistor protection is recommended.

Control Connections

'LOCAL' Operation: Below is an example of the minimum hardware connections required to run the drive in 'Local' operator mode through the onboard keypad:

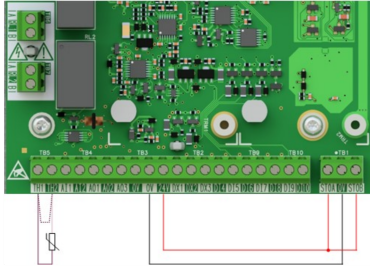

Label	Description
TH1	Motor thermistor '+' (or link to TH2)
TH2	Motor thermistor '-'
STO	STO DISABLED (drive operational)

'REMOTE' Operation: Below is an example of the hardware connections required to run the drive in the 'Standard' (Basic Speed Mode) macro in 'Remote' operator mode:

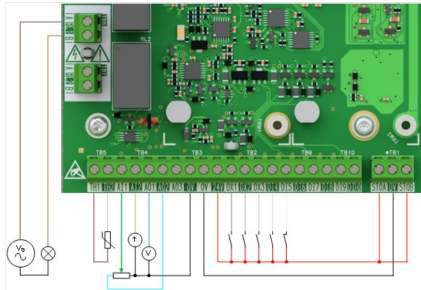

Label	Description
RL1A	110-230Vac / 24Vdc Supply
RL1B	Healthy: Relay output (to lamp)
TH1	Motor thermistor '+'
TH2	Motor thermistor '-'
AI1	Setpoint (%): 0-10V input
AI2	Setpoint Trim (%): 4-20mA input
AO1	Speed Demand (%): 0-10V output
AO2	Value = 100%: +10V fixed output
DX1	Run Forward: 24V input
DX2	Remote Reverse: 24V input
DX3	Jog: 24V input
DI4	Not Stop: 24V input
DI5	Not Coast Stop: 24V input
STO	STO DISABLED (drive operational)

APPLY POWER TO UNIT

Display Keypad

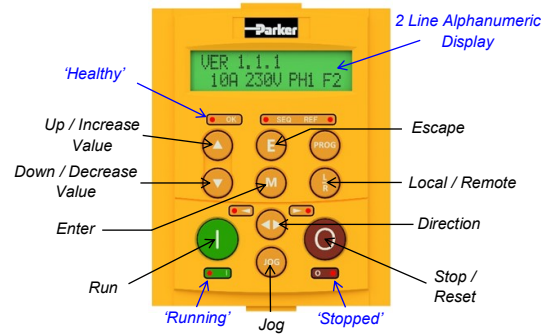

- Menu Navigation:**
- = Enters sub-menu
 - = Exits sub-menu
 - = Scrolls up and down through menu list
- Edit Parameter Value:**
- = Enters into parameter
 - = Exits parameter
 - = Increases or decreases value
 - = Decreases or increases value

Note: By default, parameter value changes are saved automatically.

On drive power-up, the display will revert to the 'Operator' menu. Press the 'E' key two times to exit to the top menu level, so "VER x.x.x" is shown on the display (where 'x.x.x' is firmware version).

Initial Drive Setup

1. Control Strategy Settings: The following parameters in the 'Control and Type' setup menu must first be set:

Parameters: Setup > Motor Control > Control and Type		
No.	Name	Value
0892	Thermistor Type	PTC / NTC
0030	Motor Type	Induction / PMAC
0031	Control Strategy	Volts-Hertz / Vector
0032	Control Type	Sensorless / Encoder Fbk

2. Motor Nameplate Settings: Next, motor parameters must be set in the 'Motor Nameplate' setup menu (Induction motor parameters shown for illustration):

Parameters: Setup > Motor Control > Motor Nameplate		
No.	Name	Default Value
0224	Base Frequency	50 (Hz)
0223	Base Voltage	400 (V)
0227	Motor Power	0.75 (kW)
0226	Nameplate Speed	1450 (rpm)
0228	Power Factor	0.71
0222	Rated Current	1.56 (A)
0182	IM Wiring	0 (FALSE)

Note: Setting 'IM Wiring' to '1' (TRUE) swaps phases V & W - inverting motor direction.

'Local' Operation

To run the drive in 'Local' operation using the onboard keypad:

1. Enable 'Local' Control Mode: Press the 'L/R' key:



Press 'L/R' key.



The 'SEQ' & 'REF' LEDs will illuminate.

2. 'Autotune' Routine (SVC & Enc Fbk Modes): If the 'Control Strategy' parameter is set to 'Vector Control', then an autotune routine must be performed prior to running the drive. A 'Rotating' autotune on an uncoupled motor is always the preferred 'Atn Mode', whenever possible.

To do this, set the 'Atn Enable' parameter in the 'Autotune' menu to 'TRUE', and press the 'Run' key to start the autotune routine:

Parameters: Setup > Motor Control > Autotune		
No.	Name	Value
0036	Atn Mode	Stationary / Rotating
0035	Atn Enable	FALSE / TRUE



ROTATING MOTOR



Press 'Run' key.



Motor 'Running' & 'Stopped' LEDs will flash and "Autotune IN PROGRESS" text is displayed.

Once the autotune routine has completed, the motor will decelerate to a stop and the drive will disable:



When the motor has come to a stop, the "Running" LED will turn off, and the "Stopped" LED will illuminate.

The drive is now ready to run in either 'Vector Control: Sensorless' (SVC) or 'Vector Control: Encoder Feedback' modes.

3. Running the Drive: In the 'Operator' menu, enter a 'Local Setpoint', and press the 'Run' key. The drive will enable, rotating the motor at the speed demanded. 'Speed Percent' provides the speed feedback (%):

Parameters: Operator		
No.	Name	Value
0459	Local Setpoint	0 -> 100 (%)
0105	Speed Percent	0 -> 100 (%)



Press 'Run' key.



Motor 'Running' LED illuminated. Motor 'Stopped' LED off.



4. Stopping the Drive: Press the 'Stop' key to bring the motor to a standstill and disable the drive:



Press 'Stop' key.



Motor 'Stopped' LED will flash during motor deceleration. When the motor has come to a stop, the 'Stopped' LED will illuminate.



'Remote' Operation

To run the drive in 'Remote' operation using push-buttons, switches or PLC's:

1. Enable 'Remote' Control Mode: Press the 'L/R' key:



Press 'L/R' key.



The 'SEQ' & 'REF' LEDs will turn off.

2. Loading a Macro: Pre-defined application macro's have been configured for remote operation. To load an Application macro, navigate to the 'Application' setup menu:

Parameters: Setup > Application		
No.	Name	Value
1150	Application	Null / Standard / Auto/Manual / Presets / Raise/Lower / PID / Aux Comms / Saved
1152	Application Lock	FALSE / TRUE
1151	Load Application	FALSE / TRUE

Set the 'Application' parameter to the desired macro i.e. 'Standard', for the 'Basic Speed Control' application (as per the 'Remote' Control Connection example).

Set the 'Load Application' parameter from 'FALSE' to 'TRUE' to load the application.

To 'lock' the application so it can not be changed, set the 'Application Lock' parameter to 'TRUE'.

3. Running the Drive: Providing the drive is in 'Remote' operating mode, 'Initial Drive Setup' is completed, and an 'Autotune' has been completed (if in SVC or Enc Fbk mode), the drive is ready to be run from the remote switches.